

Panasonic

ideas for life

2005
Video Intercom Systems



Tough Outside

Built tough to resist attacks



Door station

Microphone

Ringer button

Speakerphone

Water drain hole



Withstands external impact **A rugged metal body**

Potential intruders will have a tough time tampering with this rugged metal body. For further resistance, we used special screws that are extremely difficult to remove. Choose either gold or silver. With its solid appearance, the outside unit makes a good match with both traditional brick exteriors and more contemporary metal doors. And the body features a waterproof structure, so you can install it anywhere outdoors.

•Gold



•Silver



Lights up at night **Illuminated button**

The ringer illuminates at night, making it easier for guests to find while also lending an attractive look to your doorway. When a visitor presses the button, a chime tone sounds at the indoor color monitor unit.



Adjust to doorway shape **Camera angle control**

You get a clear view of visitors at your door thanks to a camera that sweeps over a range of 425 mm up and down and 650 mm side to side. The camera's side-to-side aim range can be adjusted to fit installation conditions.

Upper/lower range

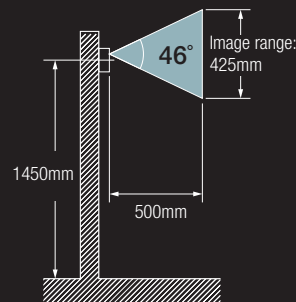

Left/right range

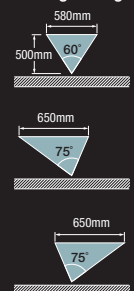

Specifications

Model No	VL-GM201A	
Main Feature	Multi Station Monitor	
Design		
System Configurations	1 monitor 1 camera	
Monitor	LCD Size	2.5"
	Communication	Handsfree or Press-to-talk
	Answer by Voice	•
	Ringer Tone	-
	Ringer Volume	-
	Receiver Volume	-
	Intercom (Monitor to Monitor)	-
	Camera Capability	1
	Camera On/Off	-
	Door Strike	• (1circuits)
	Video Out	-
	Contact closure	-
	PBX Connect	• (1circuits)
	Indication Time of Video Monitor	
	-Outside Call (Calling)	Approx. 30second
	-Monitoring	1minute
	-Outside Call (Talking)	1minute 30seconds
	-Outside Call (Press to Talk)	1minute
	Brightness	5steps
	Installation	Surface Mount / Desk Mount
Dimensions	W136 x D32 x H136mm	
Material	ABS	
Power Consumption	Stand-by30mA, Operation420mA (DC24V)	
Operating Enviroment	0°C~40°C	
Length of Cable	Monitor~Power Supply	30m (Fire Alarm Cable)
	Main Monitor~Camera	100m (CAT3 Cable)
	Monitor~Monitor	-
Option	Option Expansion Monitor	-
	Mount Style Option	Desk Mount Kit

Model No	VL-GC001A	
Main Feature	Multi Camera	
Design		
Colour	Silver & Brass	
Material	Aluminum	
View Area		
-Horizon (50cm from Camera)	Approx. Left&Right58cm(60°) Angle Change65cm(60°)	
-Vertical (50cm from Camera)	Approx. Upside43cm(46°)	
Angle Adjustment	Left & Right	
Operating Enviroment	-10°C~50°C	
Power Supply	From Monitor	
Lighted Key	• (Blue Light)	
Camera Device	CCD(250k pixels)	
Minimum Brightness	Approx. 1Lux / 50cm from Camera	
Infrared Camera	•	
Splash Resistant	•	
Dimensions	W90 x D35 x H165mm	

System diagram

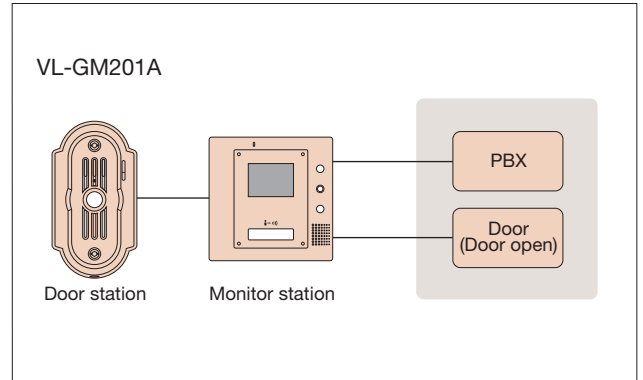

Dimensions

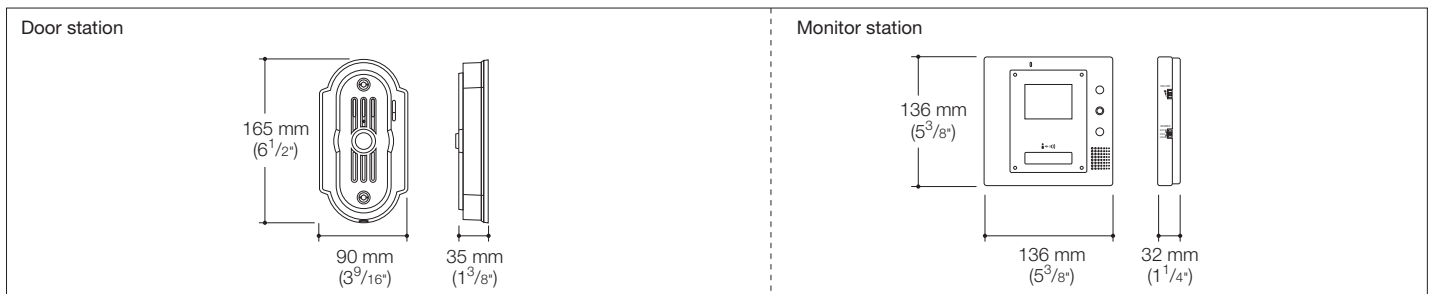

Wiring diagram

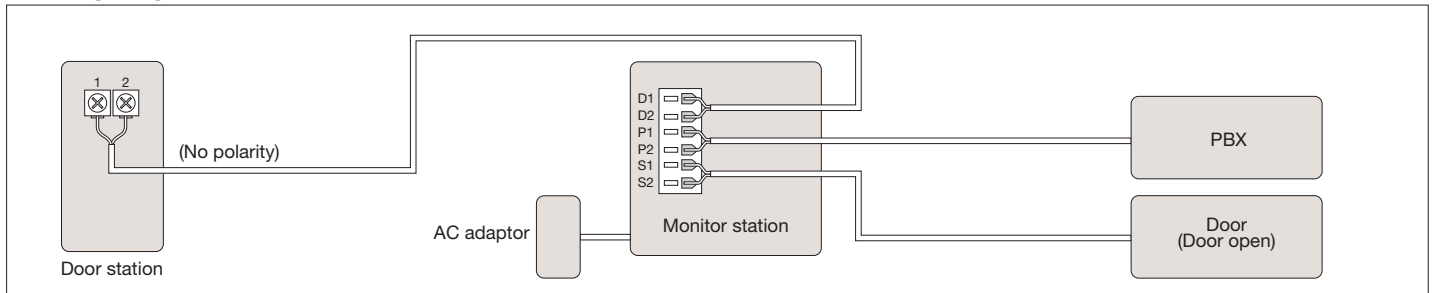

Panasonic